

OptimaLine4 Active Performance Cooling

Hangar • apron • halls • large areas • industrial and building lighting

Information

- Future PROOF> all components independently changeable
- Ready for connection and easy to install and maintain
- Easy integration into existing lighting towers
- Low weight and low wind load
- Large light-emitting and extremely powerful light output
- Highest efficiency of all system components - LongLIFE
- Different light distributions possible
- Optical cover made of safety glass IK08
- Vibration-resistant
- ThermoProtect System against overtemperature of the LED
- Optional: external control by radio
- Optional: active performance cooling



Picture shows variant flood light FU

Technical Informations

Betriebsgeräte:	CE ENEC DALI 0-10 1-10V (Dim-to-Off)
Farbe:	black
Farbtemperaturen:	3000K, 4000K, 5000K
Gehäuse:	Die-cast aluminium, powder-coated
Gewicht:	ca. 12,2 kg
Lebensdauer:	L80 60.000 - 100.000 h
Leistungsaufnahme :	540 Watt
Lichtstrom:	86000lm on 5000K
Montage:	Mounting bracket made of stainless steel: Setting range 140°, hole distance: 320mm (2x Ø12mm cable hole Ø20mm) Other types of fastening on request (for example chain suspension)
Optische Abdeckung :	Safety glass heat treated IK08
Schaltfunktionen:	Eco (on/off) Basic E1 Light E2 DALI
Schutzklasse :	IP67 SKI
Stoßfestigkeitsgrad :	IK08

BRAUN Lighting Solutions e. K. is a participant in the export initiative "Energie Effizienz – made in Germany", initiated by the Federal Ministry for the Economy and Technology. Due to the complexity of the many possible combinations of drivers and LED modules, the values shown for technical LED parameters, including performance parameters, are typical. Actual values of specific products in specific configurations may vary from these typical values. The information and diagrams contained in this document do not constitute an offer or contractual obligation. Product parameters may change as a result of technical innovation and will be undertaken without prior notice. Our manufacturing conforms to DIN EN and VDE regulations; the product conforms to European EMC regulations.

BRAUN Lighting Solutions
Nunsdorfer Ring 2-10
12277 Berlin
Germany

www.braun.lighting
info@braun-lighting.com
+49 (0)30 7 007 763-100
+49 (0)30 7 007 763-101



OptimaLine4 Active Performance Cooling

Hangar • apron • halls • large areas • industrial and building lighting

Überspannungsschutz :	10 kA
Verwendung:	Hangar • apron • halls • large areas • industrial and building lighting
Zulässige Betriebsspannung:	100-240VAC, 50/60Hz
Zulässige Umgebungstemperatur:	- 40°C up to 50°C

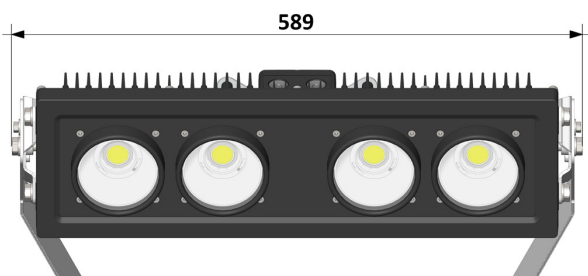

Picture shows variant 29° - 88°

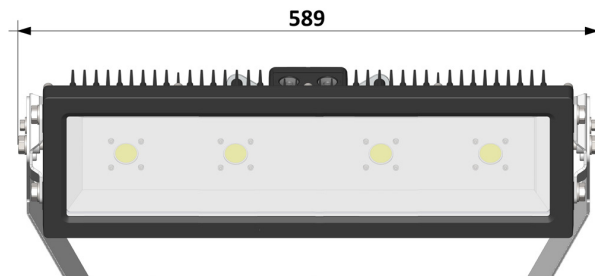

Picture shows variant flood light FU

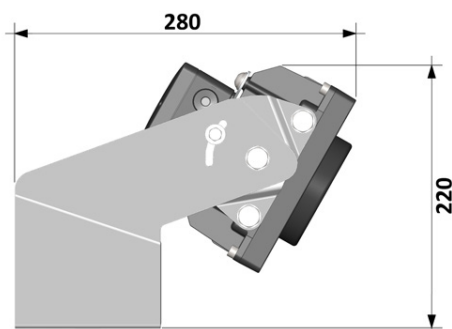

Picture shows variant 29° - 88°

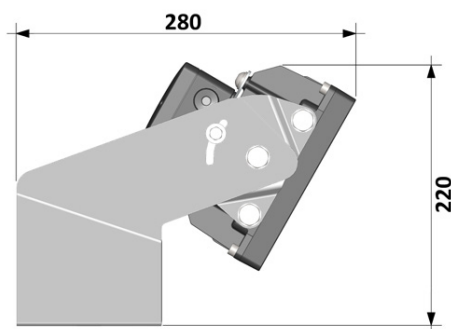

Picture shows variant flood light FU

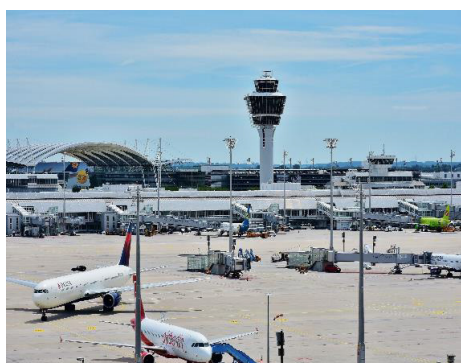

BRAUN Lighting Solutions e. K. is a participant in the export initiative "Energie Effizienz – made in Germany", initiated by the Federal Ministry for the Economy and Technology. Due to the complexity of the many possible combinations of drivers and LED modules, the values shown for technical LED parameters, including performance parameters, are typical. Actual values of specific products in specific configurations may vary from these typical values. The information and diagrams contained in this document do not constitute an offer or contractual obligation. Product parameters may change as a result of technical innovation and will be undertaken without prior notice. Our manufacturing conforms to DIN EN and VDE regulations; the product conforms to European EMC regulations.

BRAUN Lighting Solutions
Nunsdorfer Ring 2-10
12277 Berlin
Germany

www.braun.lighting
info@braun-lighting.com
+49 (0)30 7 007 763-100
+49 (0)30 7 007 763-101



OptimaLine4 Active Performance Cooling

Hangar • apron • halls • large areas • industrial and building lighting

» Variante Eco:

- power consumption: 540 Watt
 - Luminous flux: 86000lm
 - System performance: 159lm/W
 - Manually via 10-stage code switch: No
 - 0-10V | 1-10V Interface| Dim-to-Off: Yes
 - AstroDimm: Yes
 - Dali interface: No
 - Half-night switching via control voltage 230Vac: No
-

» Variante Basic E1:

- power consumption: 10 - 540 Watt
 - Luminous flux: 86000lm
 - System performance: 159lm/W
 - Manually via 10-stage code switch: Yes
 - 0-10V | 1-10V Interface| Dim-to-Off: No
 - AstroDimm: Yes
 - Dali interface: No
 - Half-night switching via control voltage 230Vac: No
-

» Variante Light E2:





- power consumption: 10 - 540 Watt
 - Luminous flux: 86000lm
 - System performance: 159lm/W
 - Manually via 10-stage code switch: Yes
 - 0-10V | 1-10V Interface| Dim-to-Off: No
 - AstroDimm: Yes
 - Dali interface: No
 - Half-night switching via control voltage 230Vac: Yes
-

» Variante DALI:

- power consumption: 1 - 540 Watt
 - Luminous flux: 86000lm
 - System performance: 159lm/W
 - Manually via 10-stage code switch: No
 - 0-10V | 1-10V Interface| Dim-to-Off: Yes
 - AstroDimm: Yes
 - Dali interface: Yes
 - Half-night switching via control voltage 230Vac: No
-

BRAUN Lighting Solutions e. K. is a participant in the export initiative "Energie Effizienz – made in Germany", initiated by the Federal Ministry for the Economy and Technology. Due to the complexity of the many possible combinations of drivers and LED modules, the values shown for technical LED parameters, including performance parameters, are typical. Actual values of specific products in specific configurations may vary from these typical values. The information and diagrams contained in this document do not constitute an offer or contractual obligation. Product parameters may change as a result of technical innovation and will be undertaken without prior notice. Our manufacturing conforms to DIN EN and VDE regulations; the product conforms to European EMC regulations.

BRAUN Lighting Solutions
Nunsdorfer Ring 2-10
12277 Berlin
Germany

 www.braun.lighting
 info@braun-lighting.com
 +49 (0)30 7 007 763-100
 +49 (0)30 7 007 763-101

